

Tft154

NATURAL TO LP CONVERSION INSTRUCTIONS:

Version Date: 2019-06-20

Kit Numbers: 85538-1



WARNING

This conversion kit shall be installed by a qualified service agency in accordance with the manufacturer's instructions and all applicable codes and requirements of the authority having jurisdiction. If the information in these instructions is not followed exactly, a fire, an explosion or production of carbon monoxide may result causing property damage, personal injury or loss of life. The qualified service agency is responsible for the proper installation of this kit. The installation is not proper and complete until the operation of the converted appliance is checked as specified in the manufacturer's instructions supplied with the kit, which necessitates the use of a calibrated CO₂/O₂ and CO combustion analyzer.

NTI boilers are factory set to operate with Natural Gas. **BEFORE OPERATING WITH PROPANE** the specified LP-Venturi Insert must be installed. Use the procedures outlined in these instructions to fully complete the Natural Gas to LP conversion for Trinity boiler model Tft154.

Kit Contents:

- Natural to LP Conversion Instructions (p/n 85539)
- Natural to LP Conversion Decal (p/n 85538)
- LP-Venturi Insert 27453 39668 (p/n 85463)

WARNING

These instructions **CANNOT** be used to convert NTI appliance models not referenced in these instructions. Contact NTI for the Natural Gas to LP conversion kit and instructions for other models.

WARNING

Failure to apply these instructions properly may result in dangerous Carbon Monoxide levels, fire or explosion leading to property damage, personal injury or death.

ATTENTION: LIQUEFIED PETROLEUM (LP) PROPANE

Liquefied Petroleum (LP) propane gas is heavier than air; therefore, it is imperative that your boiler is not installed in a pit or similar location that will permit heavier than air gas to collect. Local Codes may require appliances fueled with LP gas be provided with an approved means of removing unburned gases from the room. Check your local codes for this requirement.

1.0 Installing the LP-Venturi Insert

1. Turn the 120VAC power supply off to the boiler.
2. Remove the front cover from the unit.
3. Remove the air-inlet pipe assembly from inside the boiler (note location of feedback hose between air-inlet pipe and gas valve).
4. Remove the two screws securing the NG-Venturi Insert to the Venturi Housing see Figure 1-1.
5. Using a small flathead screw driver, gently remove the NG-Venturi Insert from the Venturi Housing (note orientation of Insert when removing).
6. Clearly label and store the NG-Venturi Insert after removing.
7. Slide the LP-Venturi Insert into the empty Venturi Housing; press firmly in place ensuring the Insert is perfectly aligned and the Insert Direction Indicator is pointing **UP**.
8. Tighten the screws to secure the LP-Venturi Insert to the Venturi Housing.
9. Install the air-inlet pipe assembly; reconnect feedback hose between air-inlet pipe and gas valve.
10. Turn the Throttle Screw clockwise (in) 3 turns.
11. Turn gas on and check for leaks in all gas piping, including the inlet connection to the gas valve, using a soap and water mixture.
12. Proceed to Section 2.0 *Gas Valve and Burner Setup*.

Figure 1-1 LP-Venturi Insert Installation and Throttle Screw Pre-set

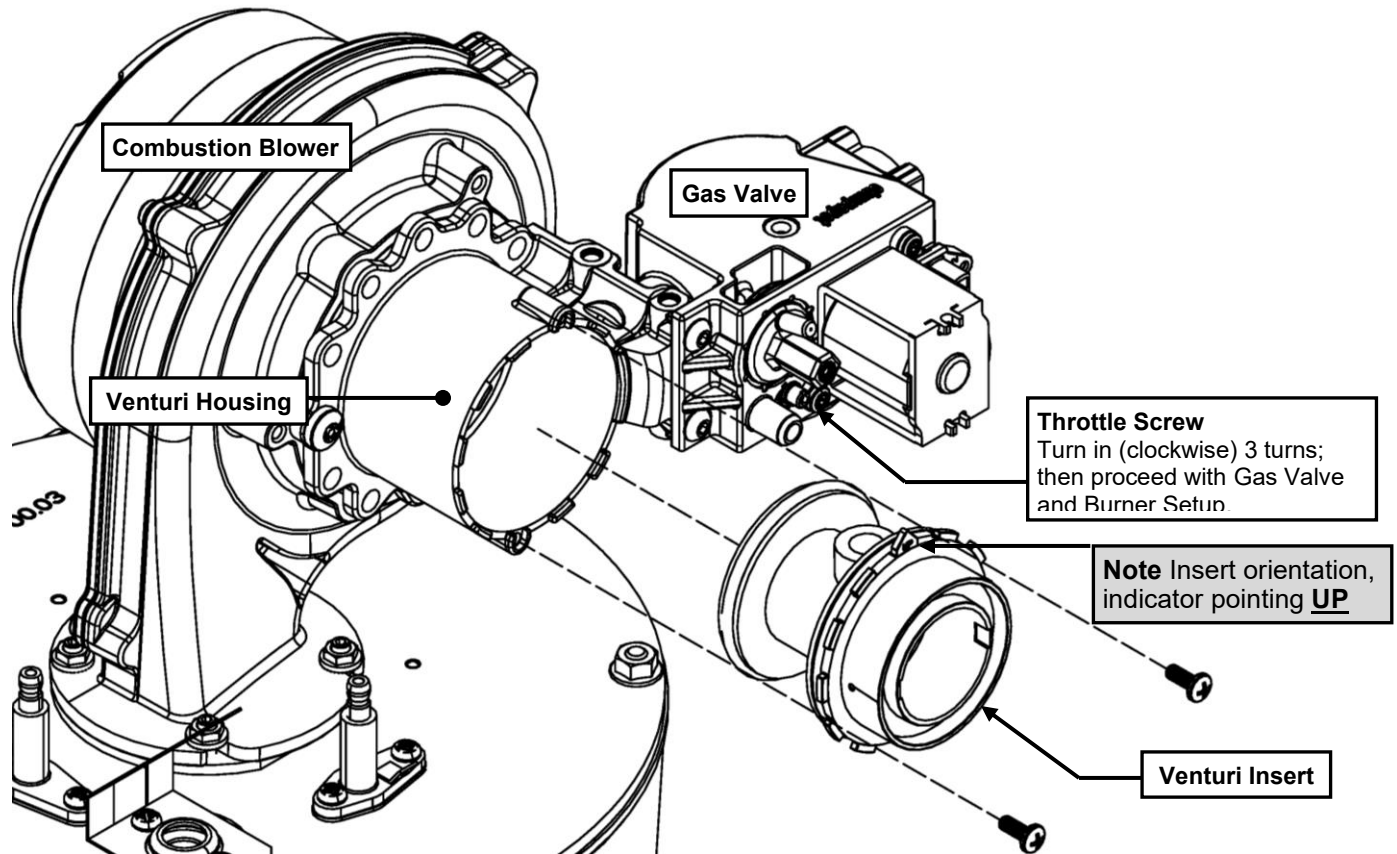

2.0 Gas Valve and Burner Setup



Failure to perform the Gas Valve and Burner Setup correctly may result in incorrect operation, component failure, property damage, serious injury or death.

Operating Sequence

Prior to commencing the Gas Valve and Burner Setup, perform the following operating sequence check:

1. Turn the supply of gas to the boiler off.
2. Set the thermostat to the highest setting.
3. Ensure the combustion fan pre-purges for a short time prior to activating the igniter.
4. Ensure the combustion fan post-purges for at least 5 seconds prior to reactivating the igniter.
5. Set the thermostat to the lowest setting and continue with the Gas Valve and Burner Setup procedure outlined below.

Combustion Calibration Procedure

To calibrate burner combustion, perform the following procedure using a calibrated combustion analyzer capable of measuring CO₂ and CO from a Natural Gas or Propane burning appliance:

1. **Set analyzer** to the appropriate fuel (Propane).
2. **Gas Line Pressure Test** – monitor gas line pressure throughout all combustion tests and verify it is maintained within tolerance. See *Gas Line Pressure Test* below.
3. **Set Throttle Screw** – operate burner to the maximum modulation rate (see Table 2-2); set combustion according to Table 1-1 using the Throttle Screw; allow time for the analyzer readings to stabilize between adjustments – record CO₂ value. See *Throttle Screw Adjustment* below.
4. **Set Offset Screw** – operate burner to the minimum modulation rate (see Table 2-2); using the Offset Screw, set the CO₂ to 0.4-0.8% lower than the value obtained during the maximum modulation rate test (e.g. if CO₂ at Max = 10.5%, then CO₂ at Min must = 9.7-10.1%). See *Offset Screw Adjustment* below.



Combustion Calibration is mandatory upon installation and during each annual service. Failure to perform the Combustion Calibration in accordance with these instructions may result in incorrect combustion leading to burner damage or excessive Carbon Monoxide concentrations causing property damage, personal injury or death.



Carbon Monoxide - Never leave the unit operating while producing Carbon Monoxide (CO) concentrations in excess of 175 ppm. Failure to follow this warning may result in serious injury or death.

Throttle Screw Adjustment

The gas valve Throttle Screw (see Figure 2-1) is used to calibrate the CO₂ concentration with the burner operating at or near the maximum modulation rate (see Table 2-2). Turning the Throttle Screw in (clockwise) decreases the CO₂ concentration. Turning the Throttle Screw out (counterclockwise) increases the CO₂ concentration. Typical adjustment required is 0 – 1/2 of a turn in or out from the position established in Section 1.0 above.

NOTE: Calibration of the Throttle Screw should only be performed with the burner operating at or near the maximum modulation rate (see Table 2-2).



Adjustments to the **Throttle Screw** may only be made by a qualified gas technician using a calibrated combustion analyzer capable of measuring CO₂ and CO. Adjustments may only be performed if the gas line pressure is maintained above minimum levels throughout the duration of the test (see Table 2-1). Failure to follow these instructions may result in serious injury or death.

Offset Screw Adjustment

The gas valve Offset Screw (see Figure 2-1) is used to calibrate the CO₂ offset at minimum modulation vs. maximum modulation. Turning the Offset Screw in (clockwise) increases the CO₂ concentration at minimum modulation rate. Turning the Offset Screw out (counterclockwise) decreases the CO₂ concentration at minimum modulation rate. Typical adjustment required is 0 - 1/8th of a turn in or out from the factory setting.

NOTE: Calibration of the Offset Screw must only be performed with the burner operating at the minimum modulation rate (see Table 2-2).



Adjustments to the Offset Screw may only be made by a qualified gas technician using a calibrated combustion analyzer capable of measuring CO₂ and CO, and only with the burner at the minimum modulation rate (see Table 2-2). Attempting to set the Offset Screw while the burner is operating at a modulation rate other than the minimum will result in incorrect combustion and may lead to burner damage or excessive CO.

Gas Line Pressure Test

The boiler gas valve is equipped with a Line Pressure Test Port; see Figure 1-1. Use the following procedure to measure the gas line pressure to the boiler to ensure it falls within the range given in Table 2-1:

1. Turn the supply of gas to the boiler off.
2. Open the bleed screw of the Line Pressure Test Port approximately 1-1/2 turns. This port is directly connected to the gas line feeding the boiler. See Figure 1-1.
3. Force 1/4" ID tubing over the housing of the Line Pressure Test Port; install the other end of the tubing to an appropriate line pressure test gauge or manometer. Ensure both ends of the tubing make a tight connection.
4. Turn the gas supply to the boiler on and check for gas leaks.
5. Observe the line pressure under static conditions and compare it to Table 2-1. The pressure will be greatest under static conditions.
6. With all other gas appliances in the application running, operate the burner to the maximum modulation rate (see Table 2-2) and compare the observed line pressure with Table 2-1. The pressure will be lowest during the maximum flow of gas, i.e. maximum modulation rate.
7. Adjust the gas line pressure to ensure the parameters in Table 2-1 are attained under all conditions. If possible adjust the line pressure to the "Nominal/Desired" value listed in Table 2-1 while the unit is operating at the maximum modulation rate.
8. Continue observing gas line pressure until combustion analysis is complete in case adjustments need to be made.
9. Complete pressure testing, remove the 1/4" tube from the test port and then return the bleed screw of the Line Pressure Test Port to the closed position.

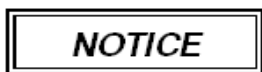

The line pressure is a function of the gas supply and is affected solely by field provided parameters such as line size and regulator settings. Under no circumstances can the boiler gas valve influence or be used to adjust the gas line pressure.



Failure to close the bleed screw of the Line Pressure Test Port will cause a severe leakage of gas, resulting in a fire or explosion causing property damage, serious injury or death.

Table 2-1 Line Pressure and Combustion Parameters

Gas	Line Pressure (inches w.c.)			CO ₂ (%)		CO (ppm) Max.
	Nominal/Desired	Min.	Max.	Min.	Max.	
Natural	7	4	10.5	8.5	9.5	175
Propane	11	8	13	10	11	175

Notes:

¹ Combustion calibration must only be performed with the burner operating at maximum modulation rate; when tested at minimum modulation rate the CO₂ must be 0.4-0.8% lower than CO₂ at maximum modulation rate.

Table 2-2 Minimum and Maximum Modulation and Input Rates

Model	Gas	Min. Modulation Rate (RPM)	Max. Modulation Rate (RPM)	Input Rate (MBH)	
				Min	Max ¹
Tft154	NG	1740	7980	15.4	154
	LP		7500		

Notes:

¹ Canada: Altitudes between 2000-4500 ft, de-rate by 10%. Consult local authorities for de-rating for altitudes above 4500ft.

² Use *Diagnostic Test*, accessed from the *Diagnostic* menu of the display, to force max. and min. modulation rates; see Appendix A – Controller and Touchscreen Display Instructions, Section 5 DIAGNOSTICS PAGE.

Figure 2-1 Gas Valve Adjustment

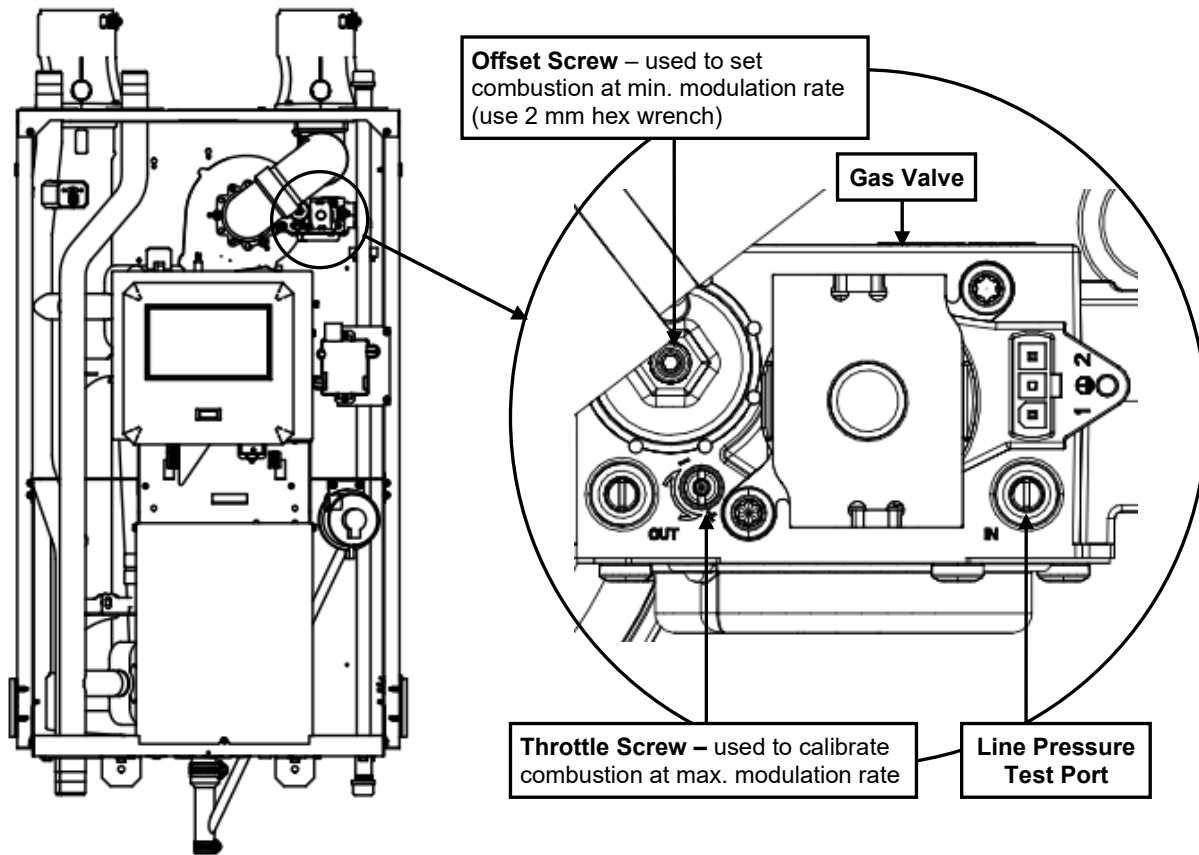

3.0 Labeling

As the certified installer of the Natural Gas to LP Conversion Kit, you must indicate on the boiler that it has been converted for use with Propane (LP) Gas:

1. **Update Rating Plate Decal** – Locate the rating plate decal on the side of the appliance, using a regular ink pen, check the box next to “Field converted to Propane Gas” and fill in the date; depress hard enough to permanently etch the decal (see Figure 3-1).
2. **Conversion Decal** - Fill out the required information on the Conversion Decal (included in this kit) and affix it to the boiler cabinet adjacent to the rating plate decal, and in a location where it can be easily seen (see Figure 3-2).

Figure 3-1 Update the Rating Plate Decal

FACTORY SET FOR NATURAL GAS Field converted to Propane Gas <input checked="" type="checkbox"/> Date: May 5, 2016	ADJUSTER A L'USINE POUR GAZ NATURAL Convertie au propane sur place <input type="checkbox"/> Date: _____	
Gas Pressure [Pression du Gaz]	Natural [Naturel]	Propane
Maximum Inlet Gas Pressure [Pression maximale d'entrée du gaz]	10.5" wc [2.6 kPa]	13" wc [3.2 kPa]
Minimum Inlet Gas Pressure [Pression minimum d'entrée du gaz]	4" wc [1 kPa]	8" wc [2 kPa]
Manifold Pressure [Pression d'admission]	0" wc [0 kPa]	0" wc [0 kPa]

Figure 3-2 Conversion Decal

THIS CONTROL WAS CONVERTED FOR USE WITH PROPANE GAS.

This appliance has been converted for use with Propane Gas, in accordance with the instructions provided with NTI kit # 85538-1, by **John Smith**, which accepts responsibility that the conversion was performed properly.

Maximum Modulation Rate adjusted to: **7500** rpm.

Reference rating plate for Propane Input and Gas Pressure

Rev. 2016-07-07 NTI Decal # 85538